

EQUIPMENT



QUIPTEC
WASTEWATER, CLEAN-GAS & ENVIRONMENTAL SOLUTIONS



BAND SCREEN

BAND SCREEN

- **High-Efficiency Debris Removal:** Uses precision perforated plates or mesh (0.5–10 mm) to reliably capture plastics, fibers, grit, and organic solids from influent water. This improves downstream process efficiency and protects pumps and other treatment equipment.
- **Self-Cleaning & Low Maintenance:** Equipped with automatic backwashing or mechanical raking systems that remove accumulated debris during operation. This reduces manual intervention, prevents clogging, and minimizes equipment downtime.
- **Space-Saving Design:** The compact and vertical configurations allow installation in channels with limited width or depth. This makes the Band Screen an excellent choice for retrofitting older plants or integrating them into new projects with tight space constraints.
- **Continuous Operation:** Designed for uninterrupted screening at high flow rates (up to 5,000 m³/h), maintaining consistent filtration performance even during peak loads or fluctuating flow conditions.
- **Energy Efficiency:** Requires significantly less energy compared to traditional bar screens because of optimized mechanical design and efficient drive components, lowering operating costs
- **Versatility:** Suitable for a wide range of applications such as municipal sewage pretreatment, industrial wastewater reuse, stormwater filtration, and agricultural runoff, providing reliable screening performance in various environments.
- **Environmental Compliance:** Effectively removes fine debris, plastics, and organics, contribute to environmental pollution, helping facilities meet regulatory discharge standards and improving overall water quality.
- **Smart Monitoring Integration:** Optional IoT-enabled sensors provide real-time data on screen performance, blockage levels, and operational status, enabling predictive maintenance and reducing unexpected failures.



Working Principle

During operation, a geared drive assembly rotates Geneva wheels which, in turn, drive the conveyor chains on both sides of the filter screen. As the screen rises, sewage held on the screen is discharged by gravity. Remaining water is washed off by a flushing system. Filtered water enters the chamber between the screens and is automatically discharged from the machine.

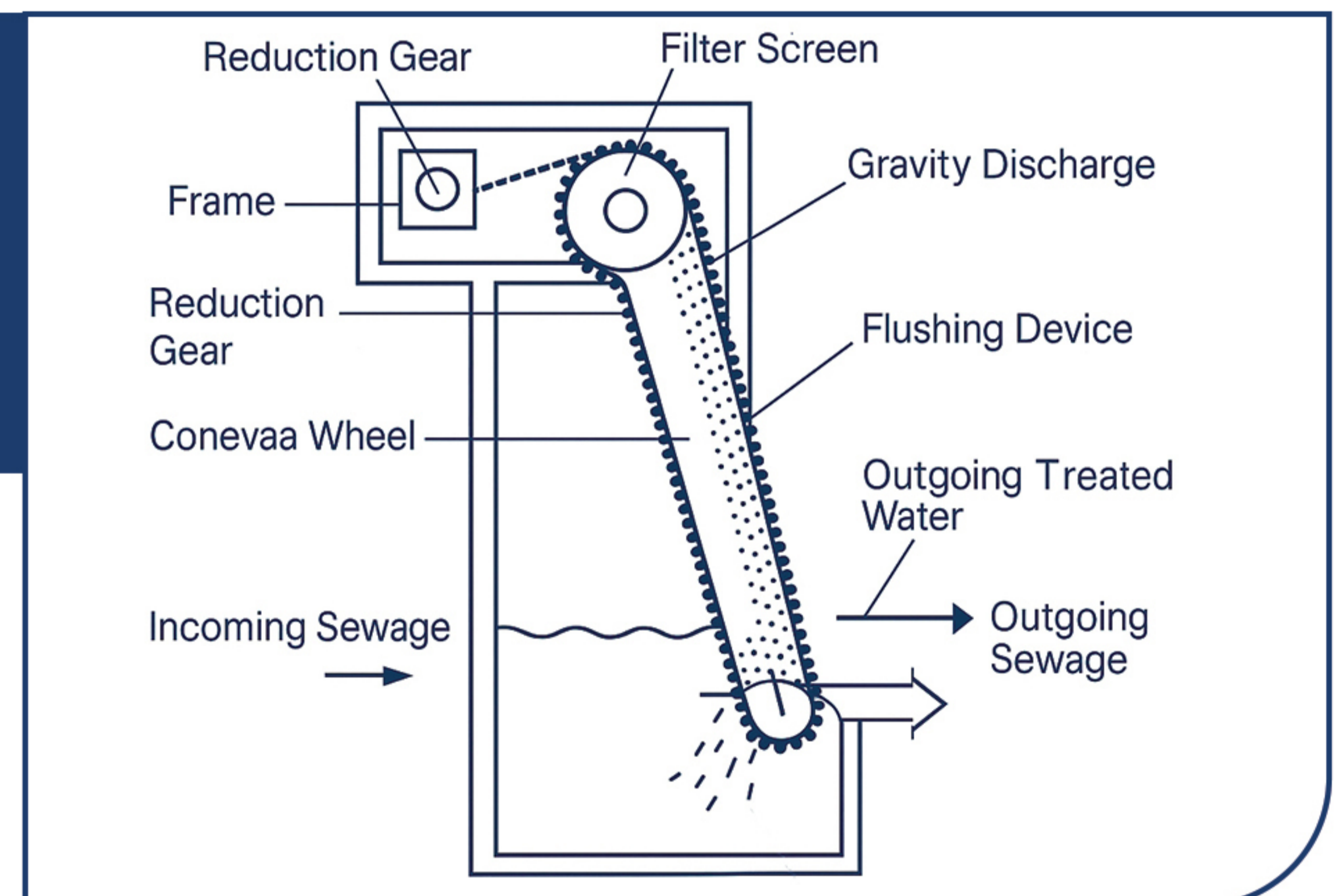

Features

Standard Features

- Precision perforated plates or mesh (0.5–10 mm)
- Automatic backwashing or raking
- Corrosion-resistant materials (stainless steel, polymers)
- Compact / vertical structural options
- Low power consumption compared to bar screens
- IoT sensor compatibility for monitoring

Options & Accessories

- Multiple Screen Widths: Models in 1000, 1200, 1400, 1600 mm plate widths
- Flexible Channel Depths: 1,000 mm to 5,000 mm
- Selectable Aperture Sizes: $\phi 2$, $\phi 3$, $\phi 5$ mm options
- Washing System Upgrades: Higher water pressure or alternative flushing designs

Specifications and Parameters

Model	AQT-IEFGS-1000	AQT-IEFGS-1200	AQT-IEFGS-1400	AQT-IEFGS-1600
Screen Plate Width (mm)	1000	1200	1400	1600
Channel Width (mm)	≥1200			
Channel Depth (mm)	1000–5000			
Screen Plate Hole Diameter (mm)	$\phi 2 / \phi 3 / \phi 5$			
Flow Rate (m/s)	≤0.6			
Allowable Water Level (mm)	≤300			
Motor Power (kW)	0.37–2.2			
Washing Water Pressure (MPa)	≥0.5			

WASTEWATER, CLEAN-GAS & ENVIRONMENTAL SOLUTIONS



 +61 (2) 40923110

 5 Moorak St
Taringa QLD 4068
Australia

 AQUIPTEC.COM.AU

 INFO@AQUIPTEC.COM.AU